



FACILITY CONNECTION REQUIREMENTS

Owensboro Municipal Utilities

TABLE OF CONTENTS

1. INTRODUCTION	4
1.1. <u>GENERAL PURPOSE</u>	4
1.2. <u>APPLICATION OF THIS DOCUMENT</u>	4
1.3. <u>GENERAL REQUIREMENTS</u>	4
1.4. <u>INTERCONNECTION STUDIES AND SPONSOR RESPONSIBILITIES</u>	6
1.4.1. <u>General</u>	6
1.5. <u>SYSTEM IMPACT STUDY / FACILITY STUDY</u>	6
1.6. <u>SUPERVISORY CONTROL AND DATA ACQUISITION</u>	7
1.7. <u>TELEMETERING AND METERING</u>	8
1.8. <u>COMMUNICATIONS DURING NORMAL AND EMERGENCY CONDITIONS</u>	9
1.9. <u>VOLTAGE AND POWER FACTOR CONTROL</u>	10
1.9.2. <u>Tap Settings of Generator Step-up and Auxiliary Transformers</u>	10
1.9.3. <u>Design and Operational Requirements</u>	11
1.10. <u>EQUIPMENT RATINGS</u>	11
2.1. <u>REACTIVE POWER REQUIREMENTS</u>	17
2.2. <u>SHORT CIRCUIT CONDITIONS</u>	17
2.3. <u>SYSTEM PROTECTION AND CONTROLS</u>	18
2.3.1. <u>Protection for 138kV System</u>	18
2.3.2. <u>Protection System Components</u>	18
2.4. <u>SYNCHRONIZING FACILITIES</u>	19
2.5. <u>SYSTEM GROUNDING</u>	19
2.6. <u>INSULATION COORDINATION</u>	21
2.7. <u>RESPONSIBILITIES DURING EMERGENCY CONDITIONS</u>	22
2.8. <u>ABNORMAL FREQUENCY AND VOLTAGE OPERATION</u>	22
2.9. <u>INSPECTION REQUIREMENTS</u>	22
2.10. <u>POWER QUALITY</u>	23
2.10.1. <u>Flicker Requirements</u>	24
2.11. <u>MAINTENANCE</u>	24
2.11.1. <u>Maintenance Requirements</u>	24
2.11.2. <u>Maintenance Coordination</u>	25
2.12. <u>PROVISIONS FOR FUTURE CHANGES</u>	26
3. TRANSMISSION INTERCONNECTION REQUIREMENTS	27
3.1. <u>INTERCONNECTIONS WITH OTHER UTILITIES</u>	27
3.2. <u>TRANSMISSION PLANNING CRITERIA</u>	27
3.3. <u>SYSTEM STABILITY</u>	27
3.4. <u>SYSTEM PROTECTION – TRANSMISSION</u>	28
3.5. <u>COMMUNICATIONS –TRANSMISSION</u>	28
4. GENERATOR INTERCONNECTION REQUIREMENTS	28
4.1. <u>SUPERVISORY CONTROL AND DATA ACQUISITION – GENERATION</u>	29
4.2. <u>SYSTEM PROTECTION - GENERATION</u>	29
4.4.1. <u>T/L Tap (138 kV) - Less than 500MW of Generation Located Adjacent to T/L</u>	30
4.4.2. <u>T/L Tap (138 kV)-Less than 500 MW of Generation Located Remote from T/L</u>	31
4.4.3. <u>Substation Interconnection Requirements</u>	32
4.4.4. <u>Transmission Interconnection Breakers</u>	32
4.5. <u>SYSTEM STABILITY</u>	33
4.6. <u>GENERATION CONTROLS</u>	34
4.7. <u>COMMUNICATIONS - GENERATORS</u>	35
4.8. <u>OBLIGATION TO SUPPLY REACTIVE POWER</u>	36
4.8.1. <u>Reactive Power Generation</u>	37
4.8.2. <u>Network Voltage Schedule</u>	38

4.9.	<u>MAINTENANCE - GENERATION</u>	38
4.10.	<u>METERING - GENERATION</u>	39
4.12.	<u>INSPECTION REQUIREMENTS - GENERATION</u>	41
5.	<u>ELECTRICITY END-USER INTERCONNECTION REQUIREMENTS</u>	42
5.1.	<u>LOAD GUIDELINES</u>	42
5.1.2.	<i>Tapping Line 100 MW Demand and Above</i>	44
5.1.3.	<i>Connecting to OMU's Bus</i>	44
5.2.	<u>POWER QUALITY - END USER</u>	44
5.3.	<u>REACTIVE POWER REQUIREMENTS - END USER</u>	45
5.4.	<u>STABILITY STUDIES</u>	45
5.5.	<u>SYSTEM PROTECTION AND OTHER CONTROLS</u>	45
6.	<u>PLANNING</u>	46
6.1.	<u>PLANNING GUIDELINES</u>	46

1. INTRODUCTION

1.1. General Purpose

This document defines the requirements for connecting transmission, generation, or end user (load serving) facilities to the OMU transmission system. The requirements established in this document are intended to ensure that facilities connected to the transmission grid do not have an adverse effect on reliability and to assure that public safety is maintained. It is recognized that while this document provides guidance on the technical issues that must be considered it should not be considered as an all-encompassing set of requirements. Specific projects must be reviewed on an individual case by case basis. This document should not be considered as a design specification manual and therefore all final designs are subject to the approval of OMU.

1.2 Application of this Document

The requirements set forth in this guide apply to OMU as well as all other entities who wish to interconnect generation, transmission; or end-use facilities to the OMU Transmission System. It applies only to facilities that are connected to the transmission grid at voltages 69 kV and above. Within this document, the entity requesting interconnection service is referred to as the "Customer".

1.3 General Requirements

A Definitions

1. "Customer" means a requester of a generation, transmission, or end-use connection to the OMU Transmission System.
2. "Party" or "Parties" refers to the Customer and OMU individually or collectively.
3. "System" means the OMU Transmission System.
4. "Point of Interconnection" means the point of interconnection to the System for new generation, transmission, or end-user facilities.

5. "Interconnection Facilities" refers to all facilities and equipment between the Customer's facility and the Point of Interconnection, including any modification, additions or upgrades that are necessary to physically and electrically interconnect the Customer's facility to the System.
6. "Required System Upgrades" refers to transmission additions or upgrades necessary for the safe and reliable interconnection of facilities to the System.
7. "Good Utility Practice" refers to any of the practices, methods, and acts engaged in or approved by a significant portion of the electric utility industry during the relevant time period, or any of the practices, methods and acts which, in the exercise of reasonable judgment in light of the facts known at the time the decision was made, could have been expected to accomplish the desired result at a reasonable cost consistent with good business practices, reliability, safety and expedition. Good Utility Practice is not intended to be limited to the optimum practice, method or act to the exclusion of all others, but rather to be acceptable practices, methods or acts generally accepted in the region, including those practices required by Federal Power Act section 215(a)(4).
8. "Point of Common Coupling (PCC)" refers to the location on the system where another customer can be served.

B Responsibilities

The Parties shall each assume responsibility for its own transmission and substation facilities connected to the System as specified in the Interconnection Agreement. The recommendations made by OMU in this document shall not relieve the Customer from complete responsibility for the adequate engineering design, construction and operation of the Customer's equipment or from any liability for injuries to property or persons associated with any failure to perform in a proper and safe manner for any reason.

1.4. Interconnection Studies and Sponsor Responsibilities

1.4.1. General

System Impact Studies (SIS) must be performed to determine the feasibility of proposed interconnection and requirements that will be needed to connect the facility to the System.

SIS(s) are conducted to determine the specific requirements for connecting to the System. The connection of the facility to the System may result in modifications at the location of the connection point as well as at remote locations due to changes in such things as load flow or short circuit capability. The effect of system stability and transfer capability will be reviewed in these studies. System interconnection studies are normally done by performing a detailed SIS.

The Customer is responsible for all costs associated with OMU or its assigned agent performing studies to determine the feasibility of proposed interconnection and requirements for connecting to the System. In general, a deposit may be required for a SIS. If the cost of the studies exceeds the deposit, the Customer shall reimburse OMU for those costs that the Customer is responsible for paying. OMU will refund any monies above the actual costs incurred. The cost of the studies can vary significantly depending upon the complexity of the proposed facility and the impact that it can have on the transmission grid.

1.5. System Impact Study / Facility Study

A SIS is performed to determine the requirements for connecting to the System. Prior to OMU beginning the SIS the Customer must contact OMU to request an interconnection to the OMU System. OMU will use the FERC Large Generator Interconnection Agreement and Large Generator Interconnection Process (LGIA/LGIP) as the basis for its interconnection process. Customers requesting interconnection service will be required to submit a completed application before any study work will commence. It is critical at this juncture that complete information is received.

Upon receipt of the interconnection request, OMU or its assigned agent will perform a SIS and if needed, a more thorough Facility Study (FS). These studies will identify all the requirements and

conditions for the Customer to interconnect to the System including upgrades required on the existing system. A detailed review of short circuit (fault duty), stability, load flow, and transfer capability analyses will be required. OMU will develop and provide cost estimates for the facilities required to interconnect with the System to the Customer. This study will be consistent with OMU Operating Procedures: TPL-001, TPL-002, TPL-003, TPL-004, and OMU Transmission Planning Process.

The load flow and short circuit studies performed will use base cases from the SERC annual model update process, while the stability analysis will utilize models that are developed for members of SERC. These studies will be conducted according to NERC Reliability Standards and will consider outages and impacts on OMU and possibly to the surrounding systems.

The typical timeline for a SIS completion is 90 days but this can vary depending on the complexity of the project. It is understood that the Customer is responsible for all costs associated with making the improvements identified by the SIS/FS if the project moves forward, including costs associated with SIS studies performed by OMU or an authorized agent(consultant).

Since OMU is interconnected and maintains a Network Operating Agreement with LGE/KU, OMU will coordinate conversations with all parties. In addition OMU facilities are within close proximity of Big Rivers Electric Corporation, and OMU will include all parties affected within the discussions. The studies will include but are not limited to: fault duty, stability, power flow, and transfer capability.

1.6. Supervisory Control and Data Acquisition

A Remote Terminal Unit ("RTU") will be required for gathering Customer load and equipment status information that will be telemetered back to OMU. OMU will provide the specifications for the RTU and the Customer is responsible for purchase and installation. The RTU must meet OMU protocol. A point assignment sheet will be provided to the Customer showing expected data type at a particular terminal point. It is the responsibility of the Customer to insure accurate translation of the point assignment sheet. The customer shall provide a data communication link

that is consistent with the RTU communications system established by OMU. The customer shall provide its data communication system plans to OMU for review prior to installation. OMU shall have the right to require modifications to the data communications plan.

Typical data requirements include the following:

- Status of interrupting devices
- MW flow
- MVAR flow
- Amps-three phase and per phase
- Power factor
- Voltage at interconnection point

1.7. Telemetry and Metering

OMU shall specify, own, and maintain all meters and metering devices (including remote terminal units) used to measure the delivery and receipt of energy for payment purposes. The revenue metering package consists of a primary revenue meter and a secondary revenue meter as a backup. The secondary revenue meter will be polled in case of failure of the primary revenue meter and utilized for billing purposes. If both meters should fail, OMU will use a metering translation process to determine the usage. This process Meter accuracy will be maintained within +/- 1%. Meters in service are tested by OMU on an annual basis, or as requested by the Commission, or any other lawfully constituted authority having jurisdiction over meter accuracy. A voice telephone extension for the purpose of accessing OMU's dial-up metering equipment and for communicating with the designated OMU operations center shall be provided by the Customer at its expense.

At a minimum, generator and load metering data requirements shall include the following:

- kW
- kWh
- kVAr, leading and lagging
- kVAr-hour
- kV² hour
- Voltage (to monitor voltage schedule compliance)

OMU will provide KQ and kVar data pulses to the Customer upon request. The preferred method of data transfer is digitally through a LAN port on the meter or a solid state pulse initiator. All

metering should be designed for loss compensation, bi-directional, proper CT's & PT's and back-up as required to meet reliability criteria.

All metering instrument transformers installed must be strictly in accordance with the latest version of IEEE Standard C57.13 and, if applicable, ANSI Standard C93.1. The Metering Equipment installed must be capable of providing the minimum data specified by OMU.

1.8. Communications During Normal and Emergency Conditions

Complete, precise, and timely communication is an essential element for maintaining reliability and security of a power system. OMU and the Customer shall establish a point of contact that shall have the authority and capability to operate Customer facilities according to the instructions of OMU or the appropriate operating entity. Under normal operating conditions, the major link of communication with various interconnects shall be by telephone lines. OMU and its Customer shall maintain communications which shall include, but not be limited to, system paralleling or separation, scheduled or unscheduled shutdowns, equipment clearances, periodic load reports, maintenance schedules, tagging of interconnection interrupting devices, meter tests, relay tests, billing, and other routine communication. All Customers who are interconnecting generation facilities shall have provisions to obtain approval from OMU prior to starting generation and connecting it to the System. All Customers who are interconnecting transmission facilities shall have provisions to obtain proper clearances from OMU prior to commencing work on the Customer facility. In case of emergency or abnormal operating conditions, various communication channels may be used depending on the interconnect category as described in Sections III, IV, and V. Emergency telephone numbers must be agreed upon by both parties prior to the actual connect date. In case of general widespread area announcements, OMU, the Reliability Coordinator-TVA, or SERC may also use public announcements through radio and television stations. In addition operators and end users should communicate the following:

- System operations
- VAR support
- Adjustments in real or reactive generation net output
- Tripping of generating unit
- Starting of generating unit
- Implementation of emergency communications procedures
- Transmission facility restoration efforts

1.9. Voltage and Power Factor Control

The interconnection shall not result in any condition where the voltage excursion shall exceed NERC, SERC or OMU requirements. Voltage limits observed on the OMU 138kV and 69kV transmission facilities are between +/- 5.0% of nominal except in the case that specific equipment may be identified as more restrictive.

1.9.1. Network Voltage Schedule

All generators are expected to maintain the voltage schedule as required by the Transmission System Operator within the reactive capability of the generating units. To satisfy applicable NERC Reliability Standard(s), OMU requires all generator owners/operators to keep detailed records of when each generating unit does not comply with the Transmission System Operator's voltage schedule. The generator owner/operator shall be responsible for providing detailed reports on voltage deviations from the acceptable voltage ranges for a specified time period when requested by OMU, TVA, SERC or NERC (within 30 days of the request).

1.9.2. Tap Settings of Generator Step-up and Auxiliary Transformers

Generator step-up and auxiliary transformers shall have their tap settings coordinated with the System voltage requirements. Anytime the generator plans to replace any of the step-up or auxiliary transformers, the generator shall supply data relating to the transformer (e.g. size and type, available tap settings, impedance data, loss data etc.) to OMU for the purpose of determining the optimum tap setting. When tap changes are necessary, OMU shall provide the Generator Owner with a report that justifies the required tap setting changes and technical justification for these changes.

As required by applicable NERC Reliability Standards, the Generator Owner shall maintain detailed records of each generator step-up transformer and auxiliary transformer that shall include type of transformer, rating, nominal voltages, existing and available taps, impedance and loss data. It shall be the responsibility of the Generator Owner/Generator Operator to provide the above information on step-up and auxiliary transformers (within five business days) when requested by OMU, SERC or NERC.

1.9.3. Design and Operational Requirements

OMU requires generators to meet the following design and operational requirements described in NERC Reliability Standard FAC-001. Design requirements include the following:

- The internal plant electrical system design (e.g., transformers, tap settings, motors & other loads, generator/exciter, voltage regulator) should not restrict any mode of project operation within System's voltage range and regulation.
- Transmission interconnected equipment should have the tap ranges and self-regulation necessary to operate within System's voltage range.
- Voltage regulator load compensation, if required, to control voltage at a point beyond the generator terminals.
- Voltage regulator droop compensation, if required, for generators whose terminals are directly connected (i.e., cross-compound, hydra)
- Coordination of excitation system settings with OMU.
- Transmission interconnection impact on adjacent areas' voltage or reactive compensation devices.

The following operational requirements must be adhered to:

- Load and/or generation operation to be within the acceptable voltage range and regulation as specified by OMU.
- Generator voltage regulator to be operated in automatic modes.
- Generator to maintain voltage schedules on transmission as required by the OMU System Operator or the Reliability Coordinator.
- Any reactive compensation devices to be coordinated with OMU.

1.10. Equipment Ratings

All current carrying equipment and devices shall be designed to carry the maximum loads that are predicted and used in load flow analysis. Facility loading exceeding "nameplate" or "normal" design capacities is only acceptable when allowed by manufacturers design documentation or standard industry practices. OMU shall have the right to review Customer design and specifications to verify that equipment ratings are consistent with OMU criteria. Equipment ratings must meet requirements identified in system studies, latest industry standards (ANSI, NEMA, IEEE), and OMU equipment specifications. Specific requirements are listed below.

Power Transformers

Power transformers shall be designed, built, and tested in accordance with the latest version of ANSI 57 series, IEEE, NEMA, or any other applicable industry standard, except any specific requirements stated below.

Coolant

The transformer shall contain a dielectric fluid (mineral oil) that has less than one (1) ppm polychlorinated biphenyl (PCB). This shall be certified on the transformer test report, and on a label permanently affixed to the transformer near the nameplate.

Taps

De-energized tap voltages shall be in accordance with the following:

Voltage Class	Tap Voltage				
69 kV	65500	67275	69000	70725	72450
138 kV	131000	134550	138000	141450	144900

CT Ratios

The current transformers shall have taps as follows:

600:5		1200:5		2000:5	
X2-X3	50/5	X2-X3	100/5	X3-X4	300/5
X1-X2	100/5	X1-X2	200/5	X1-X2	400/5
X1-X3	150/5	X1-X3	300/5	X4-X5	500/5
X4-X5	200/5	X4-X5	400/5	X2-X3	800/5
X3-X4	250/5	X3-X4	500/5	X2-X4	1100/5
X2-X4	300/5	X2-X4	600/5	X1-X3	1200/5
X1-X4	400/5	X1-X4	800/5	X1-X4	1500/5
X3-X5	450/5	X3-XS	900/5	X2-XS	1600/5
X2-X5	500/5	X2-XS	1000/5	X1-X5	2000/5
X1-X5	600/5	X1-X5	1200/5		
3000:5		4000:5			
X3-X4	500/5	X3-X4	1000/5		
X1-X2	1000/5	X1-X2	2000/5		
X2-X3	1500/5	X1-X3	3000/5		
X2-X4	2000/5	X1-X4	4000/5		
X1-X3	2500/5				
X1-X4	3000/5				

Accessories

Liquid level indicator

Top oil thermometer

Winding hot spot thermometer

Pressure/vacuum gauge

Cooling equipment

Circuit Breakers

Circuit breakers shall be designed, manufactured, and tested in accordance with the latest revision of ANSI C37.12 or any other applicable industry standard.

High Voltage Switches Standards

High voltage switches shall be designed, manufactured, and tested in accordance with the latest revision of ANSI C37.35-1976.

Switch Designations

All switches used in the substation shall meet the operating and functionality requirements as defined by the IEEE or any other applicable industry standard.

Instrument Transformers

Test reports and certification records shall be maintained and made available to OMU upon request. Instrument transformers include wound type voltage and current transformers, and capacitive coupled voltage transformers.

Standards

Instrument Transformers shall be designed, manufactured and applied in accordance with IEEE Std. C57.13.

Accuracy

The burdens placed on instrument transformers shall be within the limits required to ensure the accuracy required by the application. Metering accuracy shall be 1%.

Surge Arrestors Connections

The high voltage terminal of the surge arrester is to be connected to the terminal of the protected equipment by the shortest and most direct path possible. The ground terminal of the surge arrester is to be connected to the grounded portion of the protected equipment by the shortest and most direct path. The grounded portion of the protected equipment is to be connected directly to the grounding electrode.

Sizing

All grounding conductors and connectors shall be of low impedance and ample current carrying capacity.

Station Service

Station service power shall be provided to operate the substation equipment, various pieces of test and maintenance equipment, and station lighting. A distribution panel shall be included that provides coordinated over-current protection from the secondary of the station service transformers to each individual A.C. load. There shall be a means of establishing a visible air gap between the distribution panel and the source.

D.C System

The D.C. system shall be comprised of an appropriately sized station battery (125 Volts D.C. nominal), a battery charger, electrical disconnect devices, and a D.C. distribution panel.

Standards

Batteries shall be sized, installed, and maintained in accordance with the latest version of IEEE Std. 485, ANSI/IEEE Std. 450, and ANSI/IEEE Std. 484.

Reliability

Batteries shall be maintained in the fully charged state by being continuously connected to a suitably sized charger that derives its energy from a highly reliable AC source.

Distribution Panel

A D.C. distribution panel shall be included that provides coordinated over-current protection from the battery to each individual D.C. load. The protective devices shall be rated for D.C. use. There shall be no cross connections between D.C. circuits.

Capacitor Banks Standards

The capacitor bank, and all its components; shall be designed, installed, and maintained in accordance with the latest versions of:

- IEEE Std 18, IEEE Standard for Shunt Power Capacitors
- IEEE Std 1036, IEEE Guide for Application of Shunt Power Capacitors
- IEEE C37.99, IEEE Guide for the Protection of Shunt Power Capacitor Banks
- ANSI C2, National Electrical Safety Code

Connections

Capacitor banks installed on the transmission system, whether utilized for VAR support or voltage control, shall be connected wye or double-wye, and may be grounded or ungrounded.

Fuses

Individual capacitor units can be of either the externally fused internally fused or fuse-less type.

Insulation

The basic impulse insulation levels (BIL) of standard capacitor bank installation on OMU's system shall be as follows:

Voltage Class	Capacitor Bank BIL (kV)
Phase-to-Phase	
69 kV	250 KV
138kV	450 KV

Sizing

The capacitor shall be sized so that when energized, the maximum voltage rise on the bus to which the capacitor bank is connected shall be limited to the value for that voltage class as approved by OMU.

Monitoring

Capacitor banks will be monitored by suitable protective devices that will provide a trip output to the disconnecting device when the voltage applied to any constituent unit of the bank exceeds 10 percent of its rating. If SCADA is installed, an alarm output will be provided to the SCADA system that will operate before the 10 percent limit is exceeded.

Switching Devices

Capacitor bank switching devices shall have either pre-insertion resistors or synchronized closing, in order to provide an effective means of reducing transients associated with switching operations of capacitor banks.

Major equipment ratings are captured on the Preliminary Design Single Line.

Insulation Levels

The following chart provides minimum insulation levels for material and equipment for the various system voltages on the OMU System:

Substation Voltage kV	Sub. Equip.	Transformers BIL		Breaker BIL	Switches BIL	Potential Transf. BIL	Bus INSULATORS BIL	**Surge Arrestors	
		POWER	Auto					Duty Cycle	MCOV
69	Bushing	350	---	350	550	30	550	60	48
	Winding	350	---						
138	Bushing	550	550	550	550	550	550	96	76
	Winding	450	450						
Dist. Sub.	Bushing	750	---	900	900*	900	900*	80	144
	Winding	750*	---						
Trans. Sub	Bushing	750	900	900	900	900	900	180	144
	Winding	750*	750*						
138 Generator Step-up	Bushing	900	---	900	900	900	900	180	144
	Winding	750	---						
	Winding	--	1425						

* The preferred practice is to provide substation equipment at full BIL ratings. In certain limited cases, environmental or regulatory limitations or impacts on existing sites or structures, reduced BIL levels can be utilized only after insulation coordination and transient network analysis studies justify their use.

****Protection levels between the arrester rating and the transformer winding provide for a minimum margin of protection that exceeds 30% for all levels. ANSI C62.22 recommends the minimum protective margin, which should exist for each of three comparisons as follows:**

1. For the front-of-wave impulse protective level and the lightning impulse protective level, the minimum protective margin should be 20%.
2. For the switching impulse protective level, the minimum protective margin should be 15%.

Seismic design of substation control houses shall meet the requirements of 7 CFR Part 1792 and are designed for Seismic Zone 1.

2.1. Reactive Power Requirements

Unless otherwise agreed, the Transmission Customer is required to maintain a power factor within the same range as OMU pursuant to Good Utility Practices. The details regarding reactive power requirements for Transmission Customer, Generator and End User are covered under each respective section.

2.2. Short Circuit Conditions

All Facilities must equal or exceed the fault duty capability necessary to meet system short circuit requirements as determined through short circuit analyses and should fully comply with the latest ANSI/IEEE standards for circuit breakers, switch gear, substations, and fuses. OMU requires the generators to meet the following design requirements described in NERC Reliability Standard FAC-001:

- Each Party is responsible for the short circuit capabilities of their own current carrying elements.
- Each Party is responsible for the ratings of their own interrupting devices. It is the responsibility of the Customer to coordinate their relays and devices with the System.
- Each Party shall supply the other existing and planned future fault current levels when requested.
- It is the responsibility of the Customer to notify OMU of any changes in their facilities that may cause an increase in fault currents (Generator and Transmission Customers).

2.3. System Protection and Controls

The Customer is responsible for providing a protection system that will protect its equipment against disturbances on the System, minimize the effects of disturbances from its facilities on OMU's equipment and System, and provide safety to the public. The system characteristics should consider minimization of equipment outage time, minimization of system outage area, minimization of system voltage disturbances. Operating voltage and proximity to a generating unit will be major considerations in the selection of the basic type of protection system relay units that will be required for protecting a transmission line that connects to System. These considerations, in conjunction with the particular stability classification determined during facility tests, will determine the extent to which protection schemes are to be incorporated in a transmission line's protection scheme.

OMU substation transmission buses should be provided with differential protection wherever a high-speed fault-clearing scheme is not already in place. Such differential relaying may be either voltage-based or current-based, however, voltage-based relaying may not be feasible where equipment with differing full winding CT ratios is applied. Fault clearing times for bus faults are not to exceed 0.2 seconds.

2.3.1. Protection for 138kV System

A minimum protection scheme for the 138 kV System shall include one primary set and one secondary set of protective relays. Each set of relays should have 3 forward impedance zones of phase and ground distance elements. It should also have instantaneous phase and ground elements for instantaneous trip plus a ground time over-current element.

2.3.2. Protection System Components

The "protection system" arrangement selected by the Customer must be compatible with the protection system used by OMU to protect the System. Compatibility will include protection philosophy, operating speed, types of communication media (power line carrier or fiber optic) and communication (carrier) frequency. The coordination study should include grounding, short circuit, stability, power quality, and coordination of protective devices. Coordination of remote trip schemes, UFLS schemes, UVLS schemes, and SPS may be required.

2.4. Synchronizing Facilities

Transmission breakers are closed to connect two energized lines only after the phase angle across the breaker is verified. This is accomplished by utilizing a synroscope located in the Power Plant Control Center. This method requires the manual closing of a sync permissive switch. The switch must be turned on to allow breaker closing. Turning on the switch energizes a synroscope, which shows the phase angle between the lines to be tied together. This method requires the Operator to determine that the angle is within limits. The Customer shall be responsible for the synchronization of generation with the transmission system.

If a transmission outage occurs that does not separate the generation from the transmission system, the reclose function on the breaker and a half scheme allows an instantaneous reclose of one breaker. This breaker will lock out if the fault still exists. Synch switches should be tested annually. OMU TOP will direct the Generator to connect to OMU Transmission Facilities. If a transmission outage occurs that does not separate the generation from the transmission system, then a second method of synchronization is used that will allow automatic reclosing relays to reconnect. The control scheme initiates a close only after a synchro-verifier relay determines that the angle and voltage are within preset limits.

2.5. System Grounding

A bus is considered to be "effectively grounded" when the following relationships are true:

- $X_0/X_1 \leq 3$
- $R_0/X_1 \leq 1$

This relationship assumes $R_1/X_1 = 0$, which is a worst case condition. If one or both of these relationships are not true, the effective grounding should be checked more precisely by referring to the curves found in the "*Westinghouse Transmission and Distribution Reference Book*". The proper curve to use should be based on the actual R_1/X_1 ratio. Any set of ratios lying below the appropriate curve marked 80% will provide effective grounding for 80% lightning arresters used on OMU's system.

The substation grounding system in general shall provide for personnel safety and enable coordinated system protection. The Substation grounding design shall meet ANSI/IEEE Std. 80,

ANSI/IEEE Std. 81, ANSI/IEE Std. 142, and ANSI C2. Calculated step and touch potentials shall be less than the maximum allowable values calculated per ANSI Std. 80. The calculations should include allowances for system load growth as well as load growth at this facility. The measured soil resistivity values (two-layer model) for the substation site, calculated and measured resistance of the substation to remote earth, available fault current and maximum substation ground grid current, calculated ground potential rise to remote earth and maximum allowable and calculated step and touch potentials shall be noted on the grounding plan drawing(s). The ground grid shall extend a minimum of 3 feet outside the fenced area. All below ground connections shall be exothermically welded. All above ground connections shall be bolted.

This procedure references IEEE 80 and NESC and specifies requirements for:

- Safety criteria: Calculated step and touch potentials shall be less than the maximum allowable voltages calculated in accordance with IEEE 80.
- Design output: Maximum and allowable touch and step potentials, ground potential rise, soil model, maximum fault and grid current, and calculated grid resistance.
- Connections: Only exothermic welds below grade and bolted connections above grade.

When the interconnecting facility is within the OMU substation fence, the interconnecting facility will be incorporated into the design and construction of the OMU ground grid. When the facility is outside of the OMU substation fence, the interconnecting facility shall have its own independent ground grid. When the OMU substation and the interconnecting facility are adjacent to each other, the grids shall be connected together. The specifics for coordination of the interties between ground grids are discussed at pre-design meetings. The ground grid to be interconnected with the OMU ground grid shall be of compatible design.

The following chart shows the required structure ground resistance on all new OMU transmission construction:

TABLE 1: STRUCTURE GROUND RESISTANCE

Type of Structure	Structure Ground Resistance			
	Ohms			
	69kV		138kV	
Wood Grounded Steel Crossarms	<u>25</u>	(30)	<u>25</u>	(30)
Concrete	<u>25</u>	(30)	<u>25</u>	(30)
Steel	<u>25</u>	(30)	<u>25</u>	(30)

Values in parentheses are maximum allowable values.
 Values underlined are optimal.

Grounding and shielding designs have been standardized to protect the system against most normal over current events common to Kentucky.

2.6. Insulation Coordination

Insulation coordination is the selection of insulation strength. Insulation coordination must be done properly to ensure electrical system reliability and personnel safety. Basic Surge Level (BSLs), surge arrester, conductor spacing and gap application, substation and transmission line insulation strength, protection, and shielding shall be documented and submitted for evaluation as part of the interconnection plan.

OMU's standard is to shield substations and transmission lines from direct lightning strokes and to provide line entrance arresters at transmission line terminals. Surge arresters are also applied at major components and systems.

Interconnection facilities to be constructed in areas with contamination shall be properly designed to meet or exceed the performance of facilities not in a contamination area with regard to contamination caused outages.

2.7. Responsibilities during Emergency Conditions

OMU may, consistent with Good Utility Practice, take whatever action or inaction with regard to its System it deems necessary during an Emergency Condition in order to: (i) preserve public health and safety; (ii) preserve the reliability of the System; (iii) limit or prevent damage; and (iv) expedite restoration of service. OMU shall use reasonable efforts to minimize the effect of such action or inaction on the Facility. In case of emergency or abnormal operating conditions, various communication channels may be used depending on the interconnect category as described in Sections III, IV, and V. In case of general widespread area announcements, OMU, TVA, or SERC may also use public announcements through radio and television stations.

2.8. Abnormal Frequency and Voltage Operation

OMU requires its Customers to meet the design requirements described in NERC FAC-001 Planning Standard. When a Customer desires to interconnect a generating facility to OMU, the general protection settings must be submitted to OMU for review. OMU reviews and ensures that the proper coordination between OMU and Customer protection exists. OMU also ensures that Customer frequency protection meets OMU requirements and that the proper metering is in place to monitor abnormal voltage conditions.

2.9. Inspection Requirements

Each Party shall perform routine inspection and testing of its facilities and equipment, including secondary low voltage control systems, in accordance with Good Utility Practice as may be necessary to ensure the continued interconnection of the facility with the System in a safe and reliable manner. Each Party shall, at its own expense, have the right to observe the testing of any of the other Party's facilities and equipment whose performance may reasonably be expected to affect the reliability of the observing Party's facilities and equipment. Each Party shall notify the other Party in advance of its performance of tests of its facilities and equipment, and the other Party may have a representative attend and be present during such testing. If a Party observes any deficiencies or defects on, or becomes aware of a lack of scheduled maintenance and testing with respect to, the other Party's facilities and equipment that might reasonably be expected to adversely affect the observing Party's facilities and equipment, the observing Party shall provide

notice to the other Party that is prompt under the circumstance and the other Party shall make any corrections required in accordance with Good Utility Practice.

2.10. Power Quality

Any connection of a generator, transmission facility or end user load to OMU should not compromise or degrade the power quality of OMU or its existing Customers. A permanent digital fault recorder or other monitoring equipment may be deemed necessary and installed by the transmission owner at the point of common coupling to insure that Power Quality standards are met and maintained, and Power Quality events are captured and measured. The connection facility shall also meet any FERC, NERC or SERC reporting and reliability standards. Power quality may include but not be limited to the following:

- Voltage Unbalance
- Voltage Flicker
- Voltage Fluctuation
- Harmonic Distortion
- Transient over voltage
- Temporary over voltage
- Temporary under voltage
- Operating frequency
- Power factor range
- Interruption / Outage frequency as may be required by regulatory standards

Temporary Over/Under Voltage

Assuming that temporary is longer than 5 to 10 seconds, then the SCADA scan rate of 2-6 seconds will capture appropriate changes. OMU measures voltage via SCADA at appropriate delivery points (load and generation). Two alarm levels are in place for both high and low voltage. The OMU Control Center is staffed 24/7/365 and responds as needed to the mentioned alarms. OMU Control Center will alter system configuration as needed to control and maintain the voltage consistent with Table 1 of Section 1.10.

Power Factor Range

For loads a 0.95 pf is required at the time of the system peak as a minimum. For generators - Generators usually have voltage schedules and these policies and practices indicate the power factor and reactive support required at each location.

2.10.1. Flicker Requirements

Flicker will be assessed at the Point of Common Coupling (PCC) using an instrument in compliance with IEC 1000-4-15, except that the weighting curve used to represent the response of the light bulb shall be based on the 120 volt lamp characteristics as recommended in UIE 96-10. The flicker measured at the PCC shall be 0.8 or less for the short-term flicker (P_{st}) and 0.6 or less for the long-term Flicker (P_{lt}). The P_{st} and P_{lt} values measured shall not be exceeded more than 1% of the time based on a probability distribution calculated for a one-week period.

2.10.2. Harmonic and Inter-Harmonic Requirements:

Harmonic levels will be assessed at the PCC with an instrument that can take individual samples of voltage and current waveforms and determine the probability distribution of the individual harmonic levels for both the current and the voltage. Harmonic distortion levels at the PCC shall meet the requirements of IEEE Standard 519-1992 with respect to the harmonic current components. Background harmonic voltage distortion levels at the PCC should be in compliance with the recommendations in IEEE 519-1992. In addition, the individual inter-harmonic currents shall be limited to 25% of the values in IEEE 519-1992 and the THD calculation shall include the inter-harmonic components. The Inter-harmonics shall be calculated in 10 Hz increments. The current distortion levels specified in IEEE 519-1992 shall not be exceeded by more than 5% of the time based on a probability distribution calculated for a one-week period.

2.11. Maintenance

2.11.1. Maintenance Requirements

The Customer shall be responsible for the design, construction, installation, maintenance, and synchronization of generation with the transmission system and ownership of all Interconnection Facilities located on its side of the Interconnection Points. OMU shall be responsible for the design, construction, installation, maintenance, and ownership of all Interconnection Facilities located on OMU's side of the Interconnection Points.

In order to perform certain maintenance, testing, and repair activities, OMU 's transmission lines) must be de-energized. Under this condition, station service power may be interrupted to the Customer. OMU will require periodic transmission line(s) outages to perform protective relay

maintenance. OMU will coordinate protective system checks during these outages with the Customer. OMU's circuit breaker(s) are required to be opened periodically in order to exercise the breaker mechanism. In instances where the breaker has not been operated for an extended period, OMU may manually operate the breaker. OMU will coordinate this and any other circuit breaker maintenance with the Customer.

OMU or the Customer may request, from time to time, routine switching of each other's equipment. In such cases, OMU and the Customer will provide reasonable notice to the other Party of any equipment switching that affects electrical service to the other Party.

2.11.2. Maintenance Coordination

Complete, precise, and timely communication is an essential element for maintaining reliability and security of a power system. Under normal operating conditions, the major link of communication with various interconnects shall be by telephone lines. OMU and its Customer shall maintain communications which shall include, but not be limited to, system paralleling or separation, scheduled or unscheduled shutdowns, equipment clearances, periodic load reports, maintenance schedules, tagging of interconnection interrupting devices, meter tests, relay tests, billing, and other routine communication.

The Parties shall coordinate inspections, planned outages, and maintenance of their respective equipment, facilities and systems so as to minimize the impact on the availability, reliability and security of both Parties' systems and operations.

Each Party shall provide the other with reasonable notification for routine maintenance, operational tests, inspection activities and Revenue Meter tests. For such activities that do not require major equipment or system outages, the Party performing the maintenance shall provide the other Party with at least twenty-four (24) hours prior written notice. For such activities that will require major equipment or system outages, the Party performing the maintenance shall provide the other Party with not less than five business days prior written notice. All transmission switching will be done through OMU Control Center for scheduled and

unscheduled maintenance. The notification provided by the facility owner/operator responsible for regular scheduled maintenance of its equipment should include but be not limited to:

- Circuit Breakers
- Generators
- Power Transformers
- Protective relays
- Revenue metering
- Communications
- Trip circuits
- Interrupters
- Power DC sources
- Grounding system
- Transmission Facilities

2.12. Provisions for Future Changes

Either Party shall notify the other in advance of any changes in their respective facilities which reasonably can be expected to affect the proper coordination of protective devices of either party. In no event shall OMU be obligated to pay all or any part of the costs resulting from any relocation or rearrangement of the Interconnection Facilities which is initiated by the Customer. OMU and Customer shall discuss proposed relocation and rearrangement of the Interconnection Facilities prior to the commencement of such relocation or rearrangement. The Customer shall pay for or perform, or shall cause to have paid for or performed, such relocation or rearrangement, provided that nothing herein shall deprive OMU any right it has to challenge the necessity of any such relocation or rearrangement prior to commencement. The Customer shall provide, at its expense, all protective devices required by OMU to conform to Good Utility Practices.

Once modifications have been approved, OMU will work in association with the OMU Transmission Operator to schedule outages if necessary that may affect system operations, or require specific switching schedules to install facilities. Requirements from the facility owner will be asked for in advanced and studied by OMU Engineering Department to insure proper connection is achieved, and proper OMU system modifications can be made in advance.

3. TRANSMISSION INTERCONNECTION REQUIREMENTS

3.1. Interconnections with Other Utilities

Transmission interconnections are planned such that the transmission system will be adequate to withstand the most severe single contingency condition and maintain an acceptable level of reliability.

The North American Electric Reliability Corporation (NERC) and Southeastern Electric Reliability Corporation (SERC) have established planning criteria which must be met to assure reliable electric service. In addition to the NERC Reliability Standards for transmission planning (TPL), the following criteria are used by OMU in planning the transmission system. These criteria apply to conditions of expected firm power transfers among OMU and its neighboring power systems and to the official company load forecasts that are based on "normal" weather and projected, prevailing economic conditions.

As with generating capacity, reserve capacity must also be provided in the transmission system to recognize the effects of deviations from normal weather and of load forecast uncertainty. In the application of the following criteria an allowance of 6% should be made in circuit loading and 1% in voltage drop to provide this reserve.

3.2. Transmission Planning Criteria

The transmission system should be planned to meet NERC Reliability Standard TPL-001 through TPL-004 with (i) all transmission facilities in service or (ii) with one transmission circuit or transformer out of service and one generator out of service. Under these conditions, the maximum continuous rating of any remaining transmission facility should not be exceeded.

3.3. System Stability

A stability study is required for all proposed generating units to be connected with OMU's transmission system. The unit modeling data and equipment testing requirements are covered under section MOD-010 of the NERC Reliability Standards. OMU has accepted this NERC Reliability Standard, and the follow-up measures defined by SERC, as minimum requirements.

3.4. System Protection – Transmission

Operating voltage and proximity to a generating unit will be major considerations in the selection of the basic type of primary and backup relay units that will be required for protecting a transmission line that connects to OMU's transmission grid. These considerations, in conjunction with the particular stability classification (critical or non-critical) determined during the Facility Tests, will determine the extent to which backup coverage is to be incorporated in a transmission line's protection scheme. Protection requirements for protecting lines classified as critical and non-critical are covered in the General Requirements section of this document.

3.5. Communications –Transmission

Operational issues such as maintenance outages, generator start-ups, etc. are handled by phone between the Customer and OMU.

4. GENERATOR INTERCONNECTION REQUIREMENTS

This section addresses issues that are specific to connecting generating facilities to OMU's System operating in parallel to the System- In those cases where the generation is standby only it is assumed that appropriate interlocks and/or switches have been installed to prevent parallel operation.

System configurations vary depending upon the location and size of the generation that is to be connected to the System. Often the installation of large generation will require a transmission substation to be built due to the short circuit contribution and associated effects that it has on the performance of protective relaying. Generation that is connected to a delta-wye transformer can cause neutral shifts resulting in high voltage after breakers open to isolate high side faults. For this reason connecting generation to transformers with this configuration is discouraged. The determination of new transmission interconnection requirement for generation capacity additions must consider the same factors as those considered in the general section and Exhibit A of this document.

4.1. Supervisory Control and Data Acquisition – Generation

Prior to any operation of a Generator Facility, an RTU and transfer equipment acceptable to OMU shall be installed by Generator, or OMU at the Generator's expense, to gather accumulated and instantaneous data to be telemetered to a location(s) designated by OMU through use of a dedicated point-to-point data circuit(s). The communication protocol for this data circuits shall be specified by OMU. Instantaneous voltage data plus bi-directional analog real power and reactive power flow information must be telemetered directly to the locations specified by OMU.

The Generator will provide standard voice and facsimile communications at its Facility Control Room through use of the public telephone system. The Generator will also provide a 4-wire, full duplex data circuit (or circuits) operating at 1200 baud, or at other baud rates as reasonably specified by OMU. The data circuit(s) shall extend from Generators Facility to a location(s) specified by OMU Typical data requirements include the following:

- Status of interrupting devices
- MW flow
- MVAR flow
- Voltage at interconnection point
- Voltage and MVAR at generator leads

4.2. System Protection - Generation

The type, size, and location of the generation will determine the specific requirements. The intent of the requirements is to promote the safe and reliable operation of the System. There are many individual steps required to assess the viability of a given generation connection request (interconnect). Further evaluation as in the case of the Facilities Study will require a greater detail of generator and Generator Step-up Transformer (GSU) data.

These requirements apply to generation facilities that connect directly to the transmission system through the Customer's GSU and/or generator breaker. In addition to the review of the transmission connection, protection and control circuit requirements will include the interconnect protection scheme and the possibility of transfer trip logic. Since the size and variety of generation interconnections are so varied, each proposed protection scheme would be reviewed

by OMU under its specific conditions. Generator protection will generally follow the requirements of SERC Section 7.7 Generation Control and Protection. The Customer will own the Generator Step-up (GSU) transformer and will be responsible for synchronizing its facility to OMU's electrical system.

4.3. Islanding

Should the generator connect to a transmission line having other tapped load, there will be an additional requirement to prevent islanding. For the purpose of this document, islanding is defined as a generator being isolated such that it is the only source of power to a utility Customer. The Customer's protection system should be responsible for sensing abnormal frequency and trip its own generator to isolate from the System.

4.4. Transmission Line Connections

4.4.1. T/L Tap (138 kV) - Less than 500MW of Generation Located Adjacent to T/L

A transmission line tap as shown in Figure 6 can be used to interconnect 500 MW or less of generation capacity to the transmission system. This applies to generating facilities that are constructed adjacent to a transmission line. With this arrangement, loss of generation does not interrupt flow on the transmission system and loss of a transmission line does not result in loss of generation. Because of the close proximity, Customer owned GSU transformer relay protection can direct trip OMU's feeder breakers for the purpose of clearing a fault on the Customer's equipment. The Customer should reserve property for construction of the OMU owned inter-connect station.

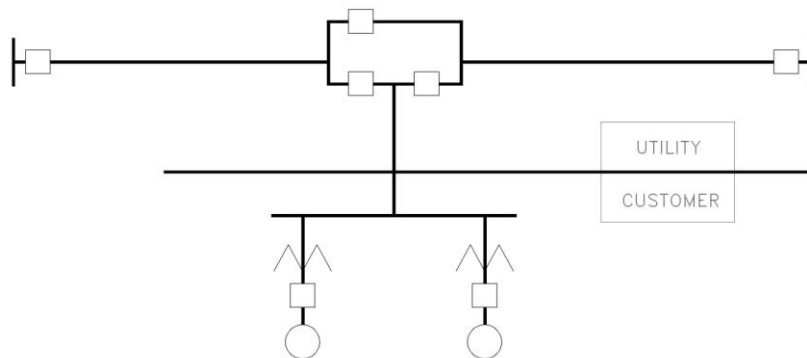
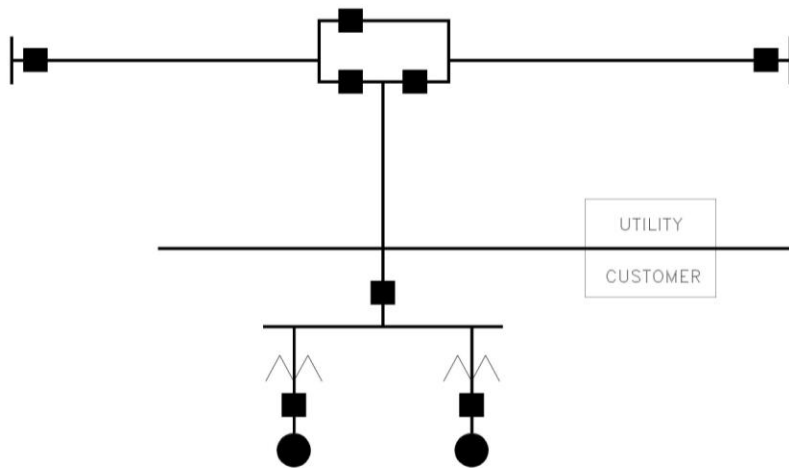

Figure 6: Line Tap - Generation Adjacent to Transmission Line < 500 MW

4.4.2. T/L Tap (138 kV)-Less than 500 MW of Generation Located Remote from T/L

A single transmission line with a ring bus at the tap point and a Customer owned interconnect breaker at the generating station as shown in Figure 7 can be used to interconnect less than 500 MW of generation capacity to the transmission system. This arrangement is used if the generating station is located remote from the transmission line. With this arrangement, loss of generation or the tap line does not interrupt flow on the transmission system and loss of a transmission line does not result in loss of generation.



<500 MW

Figure 7: Line Tap - Generation located Remote from Transmission Line

As an alternative to constructing a switching station at the tap point, the transmission line can be cut and looped in and out to a switching station located adjacent to the generating station as shown in figure 8. This arrangement can have advantages since acquiring land and permitting a new station at the tap point would not be required. Other advantages include no requirement for a Customer owned interconnect breaker as well as simplifying several protection and communication interface requirements between the plant and the interconnect site. Because of the close proximity, Customer owned GSU transformer relay protection can direct trip OMU's feeder breakers for the purpose of clearing a fault on the Customer's equipment. The Customer should reserve property for constructions of OMU owned inter-connect station.

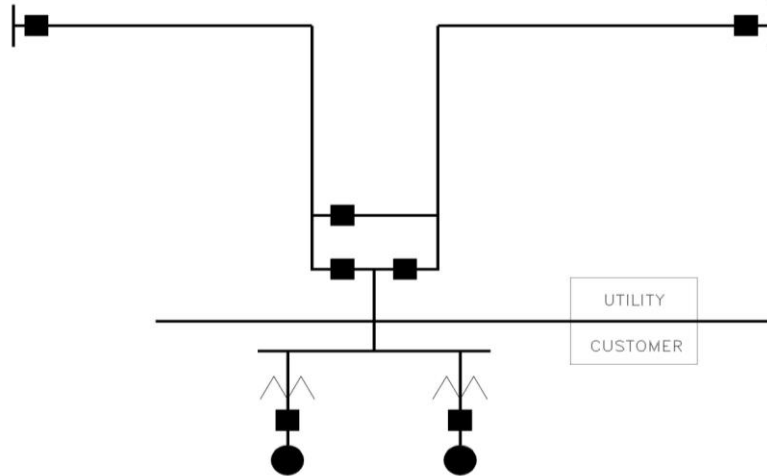

<500 MW

Figure 8: Looped Tap - Generation located Remote from Transmission Line

4.4.3. Substation Interconnection Requirements

All generation interconnection substation designs will include all switches and devices required to permit maintenance of all breakers and transmission lines without the loss of the ability to use the generation capacity when required. Small units can be bused together behind breakers if the aggregate generation behind each breaker does not exceed 500 MW.

4.4.4. Transmission Interconnection Breakers

If new transmission lines are required by the addition of generator capacity at a new or existing power station, the breaker arrangement at the existing substation will determine both the number of breakers and the breaker arrangement required for the interconnection. Line terminations that result in a six breaker or less ring bus are acceptable. If more than a six breaker ring bus is required, a breaker and a half arrangement would be used for reliability considerations.

4.4.5. Generation Interconnection Breakers

A Customer owned interconnection terminal breaker is required if the generating station is located remote from the interconnection station. Small generating units can be bused together behind this breaker as shown in figure 12 as long as the total line load does not exceed 500MW.

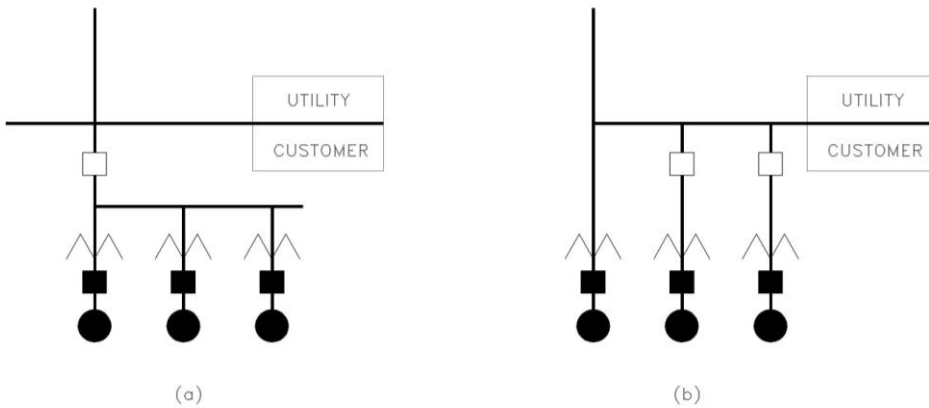

Figure 12: Generation interconnection breakers.

(a) Single breaker (b) Multiple breakers.

4.5. System Stability

The Generator shall operate its facilities with the appropriate safeguards and stabilization systems and other protective equipment necessary to protect and prevent damage to the System, including operating the facility generator unit with its speed governors and voltage regulators in service at all times. Should automatic functions not be available or should they fail to operate, including any voltage regulator, the Generator shall immediately notify OMU. The Generator shall repair these same systems as quickly as it is reasonably possible to do so, dependent upon the availability of replacement systems or parts and the stability of the System. The Generator shall accept any operating restrictions necessary during the outage of automatic function of such equipment. The Generator shall be responsible to protect its own facilities against instability resulting from disturbances on the System.

A stability analysis is required for all proposed generating units to be connected with OMU's transmission system. The NERC Reliability Standards, under System Adequacy and Security (TPL-002) describe various requirements and are summarized in that standard. The unit modeling data and equipment testing requirements are covered under section MOD-010 of the NERC Reliability Standards. OMU has accepted these NERC Reliability Standards as minimum requirements. The generator should be able to ride through Frequency deviations and meet UFLS programs.

A Power System Stabilizer (PSS) is required on all units 50 MVA and larger to ensure positive damping of power oscillation resulting from a Disturbance. It would be the Interconnecting Customer's responsibility to have PSS tuning study performed to determine gain and lead/lag time constants along with commissioning.

The requirement for reactive power and generation equipment data are described in the generator's Interconnection Agreement.

OMU will provide standard model/data sheets for the vendor to supply various generator equipment data during the initial stages of a project. It is recognized that this type of detail data may not be readily available in the final form during preliminary stages of a project. In that case, estimated typical or preliminary data is acceptable for a preliminary study. However, unit specific data is necessary to determine the Customer's requirements, and the preliminary study must be updated when appropriate data is made available. Operating restrictions may be placed based on the final updated study results. Also, it is the generator owner's responsibility to perform required tests to verify various generating equipment models and data as required by the NERC Reliability Standards.

4.6. Generation Controls

All generators connected to the System operate in automatic voltage regulation. Power factor limits are described in the generator's Interconnection Agreement. A generator voltage regulator is required to be in service and in automatic mode whenever the generator is synchronized to the system. Unless otherwise directed by the OMU operations center, the automatic voltage regulator shall control the voltage output within the reactive capabilities of the generator to maintain the nominal voltage of the connected transmission system.

To satisfy NERC Reliability Standard VAR-002-1 Requirement 1, OMU requires all Generator Owners/Generator Operators to keep detailed records as to when each on-line generating unit does not operate in the automatic voltage control mode. The Generator Owner/Generator Operator shall be responsible for providing detailed reports and a summary report for a specified time period when requested by OMU, SERC or NERC (within 30 business days of the request).

A speed governor system is required on all generators to regulate the output of the generator as a function of the system frequency. The speed governor system must respond to system frequency changes to help maintain the stability of the power system. The speed governor system shall have a speed regulation (droop) characteristic settable between three and seven percent and typically set to five percent.

OMU shall have the right to temporarily disconnect, without notice, the Interconnection Facilities from the System if, in OMU's opinion, a hazardous condition exists and such disconnection appears reasonably necessary to protect OMU's Customers, employees, agents, or property. OMU shall use its best efforts to reconnect with the Interconnection Facilities as soon as reasonably possible after it has determined that the hazardous condition no longer exists.

OMU, with reasonable notice to the Customer, shall not be obligated to accept, and may require the Customer to temporarily curtail, interrupt, or reduce deliveries of net electrical output, or net electrical output and dependable capacity when it is necessary for OMU to construct, install, maintain, repair, replace, remove, investigate, inspect, or test any part of the Interconnection Facilities or any of OMU's Interconnection Facilities, equipment, or any other relevant part of the System. The Parties will coordinate such activities to limit the adverse impact on each other.

OMU requires the generators to meet the following design requirements described in NERC Reliability Standard FAC-001:

- Load following capability
- AGC
- Reactive power output
- Remote control functions
- Coordination of generation control system settings

4.7. Communications - Generators

At the Generator's expense, the Generator shall maintain satisfactory operating communications with OMU, as designated by OMU. The Generator shall provide standard voice line, dedicated voice line and facsimile communications at its Facility control room through use of the public

telephone system. The Generator shall also provide the dedicated data circuit(s) necessary to provide necessary generator data to OMU. The data circuit(s) shall extend from the Generator Facility to a location(s) specified by OMU. Any required maintenance of such communications equipment shall be performed at Generator's expense, but may be performed by Generator or by OMU.

4.8. Obligation to Supply Reactive Power

Generator facilities connecting directly to the Transmission System at 69 kV or higher voltages will comply with all applicable NERC Reliability Standard, OMU Standards, and the generator's Interconnection Agreement, as such documents may be amended from time to time, with regard to voltage support and supply of reactive power to the System. All generator facilities connecting to the System at 69 kV or higher voltages shall operate in automatic voltage regulation. A generator voltage regulator is required to be in service and in automatic mode whenever the generator is synchronized to the System. Unless otherwise directed by OMU, the automatic voltage regulator shall, within the reactive capabilities of the generator, control the voltage output pursuant to the voltage schedule prescribed by OMU. OMU shall have the right to alter the voltage schedule as the system operating conditions may require from time to time.

When OMU declares an Emergency Condition on its Transmission System or on an adjacent transmission system, OMU shall have the authority to direct the Generator to increase or decrease real power production (measured in MW) and/or reactive power production (measured in MVar), within the design and operational limitations of the Facility equipment in service at the time, in order to maintain Transmission System security. In the event of a declaration of an Emergency Condition, a determination: (i) that the Transmission System security is in jeopardy, and (ii) that there is a need to increase or decrease reactive power production, even if real power production is adversely affected, will be made solely by OMU. The Facility operator will honor OMU's orders and directives concerning Facility real power and/or reactive power output within the design limitations of the Facility's equipment in service at the time, such that the security of OMU's Transmission System is maintained. OMU shall restore Transmission System conditions to normal as quickly as possible to alleviate any such Emergency Condition. OMU will take all

reasonable steps to allocate among all generating units and other reactive power supply resources the responsibility to provide reactive power support to OMU's Transmission System.

4.8.1. Reactive Power Generation

The Generator shall supply reactive power to the System or absorb reactive power from the System in accordance with Good Utility Practice, OMU Standards, the generator's Interconnection Agreement, applicable operational and/or reliability criteria, protocols, and directives, including those of SERC and Applicable Laws and Regulations and this Agreement. Generator shall respond to requests from OMU to increase or decrease generator reactive power output in a manner consistent with Generator's obligation to operate and control the Facility. The Generator Facility shall supply or absorb such reactive power in accordance with the voltage schedule or reactive levels prescribed by OMU but not in excess of the amount available from the Facility's equipment in operation at the time and within the manufacturer's design limitations of the Facility. OMU 's voltage schedule shall be provided to the Generator Owner to provide proper voltage control as identified in OMU Procedure VAR-001.

OMU requires the generators to meet the following design and operational requirements described in NERC Reliability Standard FAC-001:

Design requirements include:

- Internal plant systems design (e.g., transformer rating/taps/impedance, cooling systems, generator/exciter rating) should not limit continuous reactive capability.
- Transmission interconnected equipment should have the tap ranges and self-regulation necessary to accommodate the transmission system's reactive power flow requirements.
- Transmission interconnections should not have an impact on adjacent areas' reactive power flow requirements

Operational requirements include:

- Testing to verify reactive support capability per NERC Reliability Standards
- Generator step-up transformer (GSU) tap changes as necessary to meet voltage schedule and reactive support requirements

4.8.2. Network Voltage Schedule

All generators are expected to maintain the voltage schedule as required by OMU's ECS Operator within the reactive capability of the generating units. To satisfy applicable NERC Reliability Standard, OMU Standards, and the generator's Interconnection Agreement, OMU requires all Generator Owners/Generator Operators to keep detailed records as to when each generating unit does not comply with the Transmission System Operator's schedule. The Generator Owner/Generator Operator shall be responsible for providing detailed reports on voltage deviations from the acceptable voltage ranges for a specified time period when requested by OMU, SERC or NERC (within 30 days of the request).

4.9. Maintenance - Generation

OMU shall have the right, but shall have no obligation or responsibility to

- I. Observe Generator's tests and/or inspection of any of Generator's System Protection Facilities and other protective equipment,
- II. Review the settings of Generators System Protection Facilities and other protective equipment, and
- III. Review Generator's maintenance records relative to the Facility, Generator Interconnection Facilities, and/or Generator's System Protection Facilities and other protective equipment.

OMU shall maintain its facilities and equipment, to the extent they might reasonably be expected to have an impact on the operation of the facilities in a safe and reliable manner, in accordance with Good Utility Practice and in accordance with the provisions of this document. The Generator shall maintain its facilities and equipment, to the extent they might reasonably be expected to have an impact on the operation of the System in a safe and reliable manner, in accordance with Good Utility Practice and in accordance with the provisions of this Agreement. Maintenance requirements are also covered in the General Requirements section of this document.

4.10. Metering - Generation

At the Generator's expense, OMU shall, in accordance with Good Utility Practice, specify, install, own, operate, and maintain all Metering Equipment for the Interconnection Points that measure energy flows on an hour-by-hour basis or such shorter intervals as may be required by OMU. The Metering Equipment specified shall also allow OMU to have the capability to properly monitor generator imbalance conditions. The related equipment shall include instrument transformers and any of the associated communications links needed. The information provided by the metering facilities shall meet the reasonable needs and approvals of all Parties, consistent with Good Utility Practice.

All Revenue Meters shall be of advanced meter design such that they have an internal recorder and communications capability that OMU can utilize to retrieve diagnostic messages, the recorded transfer of energy between the Parties, and any other information deemed necessary by OMU.

Metering Equipment shall be as follows:

- Each Facility connected to OMU's Transmission System, including Distribution Facilities, shall have Metering Equipment installed to provide direct readings of the Facility's net bi-directional real and reactive power and energy output. The metering instrument transformers used to measure the Facility's net output shall be installed on or compensated to the high side (transmission voltage side) of the generator step-up transformer, unless otherwise agreed by the Parties.
- All plant auxiliary power transformers (non-generator step-down transformers) and lines directly connected to the System, including Distribution Facilities, shall have Metering Equipment installed to provide bi-directional real and reactive power and energy flow. Metering instrument transformers shall be connected to or compensated to the high side (transmission voltage side) of the power transformer, unless otherwise agreed to by the Parties.

All Metering Equipment installed pursuant to this document shall be routinely tested by OMU in accordance with Good Utility Practice, and such results reported to the Generator Owner. OMU, at the expense of the Generator, will test all Revenue Meters and analog equipment at least once every two years. The Generator may request any number of additional meter tests and will compensate OMU for the actual cost incurred to test such meters. If the Metering Equipment is found to be inaccurate by more than one-third of one percent (1.0%) of full meter registration or are otherwise defective, they shall be repaired, adjusted, or replaced by OMU at the expense of the Generator. No adjustment shall be made for meter readings made prior to the point in time halfway between the time of the last test that showed the Revenue Meters and analog equipment in question to be functioning accurately and the time the subsequent inaccuracy is corrected, except by agreement of the Parties. In any case, all Revenue Meters and analog equipment shall be tested at least once every two (2) years.

Unless otherwise mutually agreed, all meters shall be sealed, and the seals shall be broken only by OMU upon occasions when the meters are to be inspected, tested, adjusted or re-calibrated in accordance with Good Utility Practice.

Metering requirements are also covered in the General Requirements section of this document.

4.11. Responsibilities during Emergency Situation - Generation

Each Party agrees to comply with NERC, SERC, TVA-RC Emergency Condition procedures and OMU and Generator Owner Emergency Condition procedures, as applicable, with respect to Emergency Conditions.

OMU shall provide the Generator with notification that is prompt under the circumstances of an Emergency Condition that may reasonably be expected to affect the Generators operation of the Facility, to the extent OMU is aware of the Emergency Condition. The Generator shall provide OMU with notification that is prompt under the circumstances of an Emergency Condition which may reasonably be expected to affect OMU's Transmission System, to the extent the Generator is aware of the Emergency Condition. To the extent the Party becoming aware of an Emergency Condition is aware of the facts of the Emergency Condition, such notification shall describe the

Emergency Condition, the extent of the damage or deficiency, its anticipated duration, and the corrective action taken and/or to be taken, and shall be followed as soon as practicable with written notice.

In the event of an Emergency Condition, the Party becoming aware of the Emergency Condition may, in accordance with Good Utility Practice and using its reasonable judgment, take such action as is reasonable and necessary to prevent, avoid, or mitigate injury, danger, and loss. In the event the Generator has identified an Emergency Condition involving the System, the Generator shall obtain the consent of OMU ECS personnel prior to manually performing any switching operations upon the Generator Owners Switch unless, in the Generator's reasonable judgment, immediate action is required.

Facility may be called upon by OMU during a potential or actual Emergency Condition to mitigate such Emergency Condition by, but not limited to, requesting the facility to start-up, shutdown, increase or decrease the output of the facility. Responsibilities during emergency situations are also covered in the General Requirements section of this document.

4.12. Inspection Requirements - Generation

The Generator shall grant OMU right of access to their facility for purposes of conducting inspections, observing tests, and auditing records required by NERC standards and established reporting procedures. Inspection requirements are also covered in the General Requirements section of this document.

Each Party shall perform routine inspection and testing of its facilities and equipment, including secondary low voltage control systems, in accordance with Good Utility Practice as may be necessary to ensure the continued interconnection of the Facility with the System in a safe and reliable manner. Each Party shall, at its own expense, have the right to observe the testing of any of the other Party's facilities and equipment whose performance may reasonably be expected to affect the reliability of the observing Party's facilities and equipment. Each Party shall notify the other Party in advance of its performance of tests of its facilities and equipment, and the other Party may have a representative attend and be present during such testing.

If a Party observes any deficiencies or defects on, or becomes aware of a lack of scheduled maintenance and testing with respect to, the other Party's facilities and equipment that might reasonably be expected to adversely affect the observing Party's facilities and equipment, the observing Party shall provide notice to the other Party that is prompt under the circumstance, and the other Party shall make any corrections required in accordance with Good Utility Practice.

5. ELECTRICITY END-USER INTERCONNECTION REQUIREMENTS

5.1. Load Guidelines

Transmission facilities may be used for providing service to commercial, industrial, municipal, cooperative, and cogeneration Customers when the use of distribution feeders is not practicable. Generally, the use of transmission facilities should be considered for the following conditions:

- All loads and generation over 20 MVA
- Locations remote from distribution facilities
- Remote locations where distribution facilities are not adequate
- Loads with nonstandard voltage requirements
- Loads having large surge requirements

The feasibility of serving Customers direct from transmission requires a comprehensive study and coordination. Factors to be considered prior to agreeing on a Customer connection is as follows:

- Economics of alternates
- Customer parallel generation
- Transmission line tap or loop length
- Customer transformer characteristics
- Customer switching
- Effect on protective relaying at remote terminals
- Problems of large through power on looped lines
- Extent of Customer facilities

The following diagrams indicate the facilities arrangement for normal service 69 kV and above.

5.1.1. Tapping Line below 100 MW Demand

If the tap line is long enough to require a circuit breaker, a single breaker with an air break switch bypass will be considered for 138 kV or below. Above 138 kV, two breakers in parallel or a three-breaker ring may be used. If a breaker is required solely by extensive Customer facilities, the Customer provides the breaker.

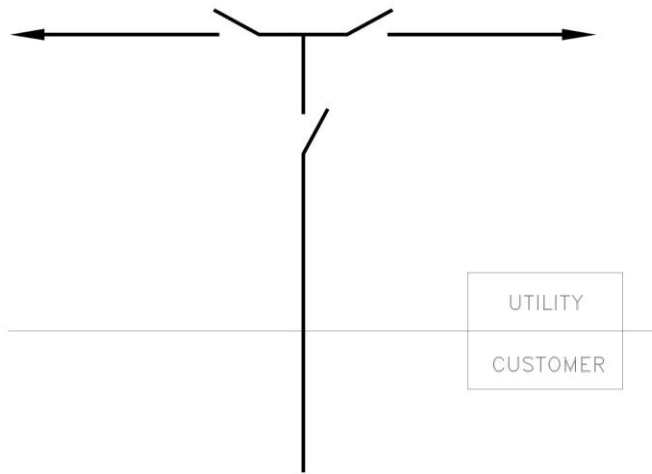

Figure 13: Tapping Line below 100 MW Demand.

Where two circuits are available, a preferred-alternate scheme may be applied. OMU will conduct a review and determine the need for equipping switches with vacuum attachments for breaking parallel or line charging currents. In general, 138 kV switches are judged on a case by case basis depending on load and recovery voltage as to the need of vacuum switches.

The following are typical preferred minimum load demands for connecting to existing transmission lines:

- 138 kV - 20 MW

5.1.2. Tapping Line 100 MW Demand and Above

The addition of Customer load in excess of 100 MW's should be connected to OMU's transmission system as shown in Figure 14 below.

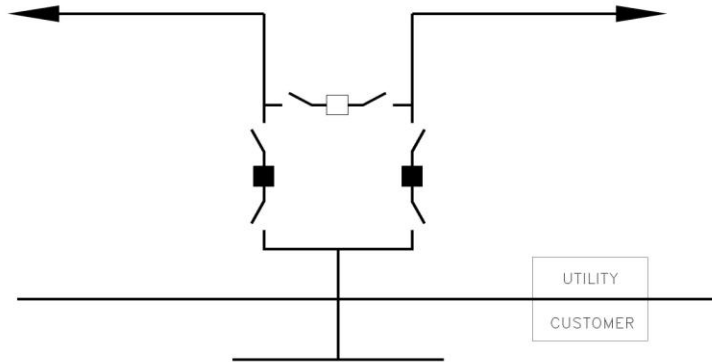

Figure 14: Tapping Line 100 MW Demand and Above

5.1.3. Connecting to OMU's Bus

In those cases where it may be practicable to connect to an existing transmission substation bus OMU will evaluate the request on a case by case basis. The following are typical preferred minimum load demands for connecting to existing substation busses:

- 138 kV - 50 MW
- 69 kV - 25 MW

For situations where demands are less than the above, but a circuit breaker is required due to a long transmission line to the delivery point, a breaker may be connected to the substation bus instead of the line. Existing substation busses may be tapped at two places with two breakers provided by OMU for 100 MW Demand or more.

5.2. Power Quality - End User

Power Quality requirements for end-user Customers are covered in the General Requirements section of this document.

5.3. Reactive Power Requirements - End User

Unless otherwise agreed, the Transmission Load Customer is required to maintain a power factor within the same range as OMU pursuant to Good Utility Practices. The transmission Customer shall maintain a minimum power factor of 95.0% (lagging) at transmission level delivery points or as specified in the Service Agreement where applicable. Details regarding reactive power for generators are included in the Generator Connection Requirements section of this document.

5.4. Stability Studies

If an industrial Customer has internal generation, a stability study may be required. The Customer must supply a detailed description of the Customer's load characteristics, internal distribution system representation, generating equipment models and data, etc. The Customer will reimburse any and all expenses incurred by OMU in performing such a study. Details regarding stability studies for generators are included in the Generator Connection Requirements section of this document.

5.5. System Protection and Other Controls

The end user is responsible for providing a protection system that will protect its equipment against disturbances on the System and minimize the effects of disturbances from its facilities on OMU's equipment and the System. For facilities larger than 100 MW, the End-User shall provide OMU its planned protection system for OMU to review to ensure proper coordination of the protection schemes. In addition, if Under Frequency Load shedding is required, 30% of the facilities load must be shed in 5% increments beginning at 59.5 Hz, 59.3 Hz, 59.1 Hz, 58.9 Hz, and 58.7 Hz.

6. PLANNING

6.1. Planning guidelines

GENERAL CRITERIA

OMU endeavors to maintain a degree of reliability in electric service that satisfies the average Customer's service requirements at a reasonable cost.

The North American Electric Reliability Council (NERC) and the ten (10) regional reliability councils have established planning criteria which must be met to assure reliable service to all areas of the United States. These general criteria were included in the NERC Reliability Standards approved in September 1997. More detailed criteria are needed within each operating system to satisfy the requirements specific to that area.

OMU is a member of the SERC Region and is guided by the criteria set forth by SERC. In addition, the preceding criteria are used in planning The System. These criteria apply to conditions of expected firm power transfers among OMU and its neighboring power systems and to the official company load forecasts, which are based on "normal" weather and projected prevailing economic conditions.